

## Water press connections

There are 5 ports on the block. It does not matter which item is attached to which port.

- One port for the gauge.
- One port on the backside for the pipe going to the bladder.
- One port for the Inlet--brass hose barb.
- One port for the Outlet---valve that looks like a water faucet.
- One port for the safety relief valve. This is the valve that will open if pressure is excessive.

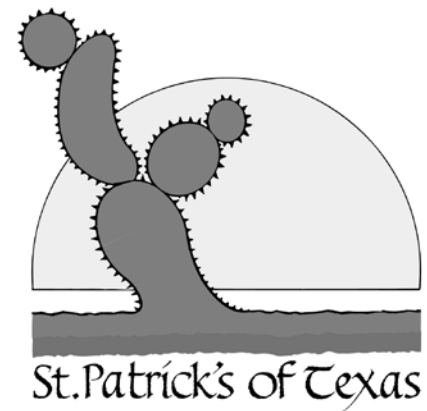

## 1) GENERAL INFORMATION

### INDEX

- 1) GENERAL INFORMATION
- 2) COMPONENT PARTS
- 3) SAFETY RULES
- 4) OPERATING DIRECTIONS
- 5) SPARE PARTS
- 6) MEMBRANE REPLACEMENT
- 7) GENERAL TERMS OF SALE

WATER PRESS art. 6 is suitable for squeezing minced apples, grapes - already separated from the bunch - and other substances without stone nor hard or sharp parts, which could damage the membrane (E).

Pressing with water press is a new and effective system that works with water pressure of mains network. Water gets into the membrane through the central shaft in stainless steel (D) (bored inside). The membrane expands uniformly outward and squeezes the product against the pierced cage in stainless steel (F). See picture 1.

Cover (B) and collecting base (G) are made of aluminium painted with epoxy powders (nontoxic). The pierced cage (F) is in stainless steel AISI 304 and the holes have a 2 mm. diameter. Membrane (E) is made of nontoxic rubber.

The pressing process by the use of water press is very fast, simple and clean.

NOISE PRODUCTION: Inexistent

IMPORTANT: The manufactory "ENOTECHNICA PILLAN SNC" declines all responsibility if manual directions are not followed or if the machine gets improper usage. If you are not sure about machine working, you should apply to the manufactory or the authorized retailer.

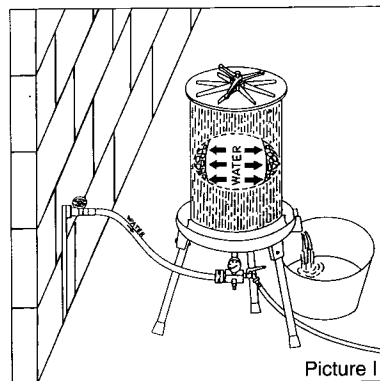

## 2) COMPONENT PARTS

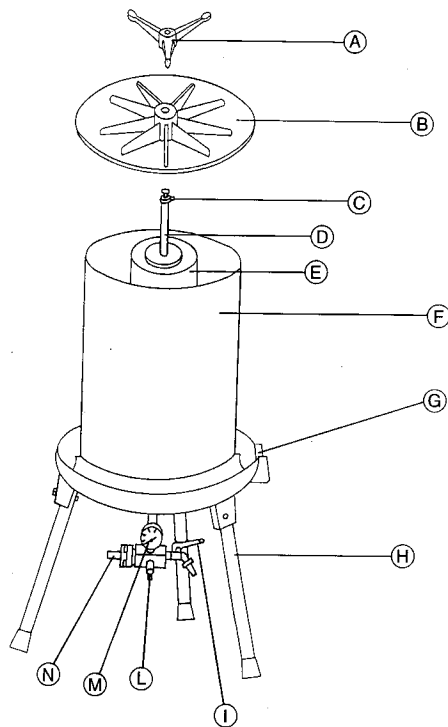

Picture II

- A) Locking crank
- B) Cover
- C) Air-relief valve
- D) Central shaft
- E) Membrane
- F) Pierced cage
- G) Collecting base

- H) Supporting leg
- I) Emptying tap
- L) Safety valve
- M) Pressure gauge
- N) Discharge

## 3) SAFETY RULES

*Improper use or incorrect upkeep may damage people or things. In order to prevent possible accidents, please pay attention to the following safety rules:*

- 1) **DIRECTIONS:** It is advisable to use the water press only after having read this manual, which in case of loss can be available by ENOTECNICA PILLAN snc Via Chiesa 12 - 36043 CAMISANO (VD) ITALY
- 2) **UTILISATION:** Prevent children and unskilled people from using the water press.
- 3) **POSITION:** Locate the machine on a flat floor, in order to ensure its stability while working.
- 4) **OPERATIONS:** As pointed out on the cover casting (B), only water must be used.
- 5) **It is FORBIDDEN to use air or other kinds of gas to inflate the pressing membrane (E).** In case of bursting due to the use of air or another gas, the firm will decline all responsibility and claim for moral and image damages.
- 6) **SAFETY VALVE:** It is absolutely forbidden to cut out or tamper with the safety rule (L), which has already been set on three atmospheres. If the valve breaks or doesn't work any more, ask immediately the manufacturer or the authorised retailer for the corresponding spare part (before using the press again).
- 7) **WARNING:** Before inflating the membrane (E) with water make sure that the cage (F) is in its housing and that the cover (B) has been properly fixed in the cage (F), as well as the crank (4) has been completely screwed on the cover (B).

## 4) OPERATING DIRECTIONS

- 1) **CLEANING:** Before starting to press it is advisable to clean thoroughly the pierced cage (F), the cover (B), the membrane (E) and the collecting base (G).
- 2) **CONNECTION:** Connect the water-main pipe (see picture 1) with the discharge (N) and connect another pipe to the water-press emptying tap (I).
- 3) **PRODUCT LOADING:** Unscrew the crank (A) and take off the cover (B). If you are going to use the gunny sack, put it into the cage (F) so that it fits closely to its inner wall. Load the product you are going to press by distributing it uniformly (this operation is very important); fold the gunny sack's rim inside the cage; put the cover (B) and screw it tight through the locking crank (A).
- 4) **AIR RELEASE:** Before turning on the delivery tap it is necessary to open the air-relief valve (C). Then you can turn on the tap. The air-relief valve has to be closed as soon as water starts coming out.
- 5) **EXTERNAL BAG:** It has to be used as antisplash protection.
- 6) **PRESSING:** It takes place automatically, since the product is entirely pressed by the pressure acting inside the water pipe (until 3 atmospheres). If there is a higher pressure the safety valve (L) starts immediately working by opening and blowing off the exceeding pressure.
- 7) **FINAL WORKING:** When you have finished pressing, close the water pipe and turn on the water-press emptying tap. After all water has been blown off, take off the cover, take out the pressing residue and repeat the operation from the beginning.
- 8) **ROUTINE MAINTENANCE:** The water press doesn't need a special kind of upkeep. Anyway, it is recommendable to keep the machine clean and to protect it from dust.

## 5) MEMBRANE'S REPLACEMENT

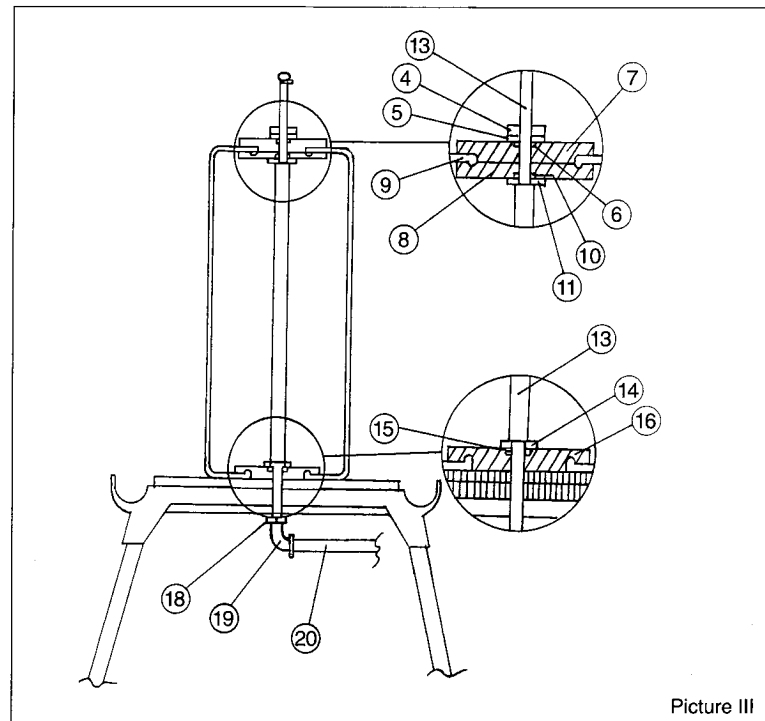

Picture III

To change the membrane observe carefully picture III and make following operations: take off locking pipe 4, remove washer 5 and flange 7; unscrew connecting pipe 20, bend 19 and lower locking nut 18. Now you can take out shaft 13 and replace the membrane. By reassembling the machine it is advisable to follow the scheme and make sure that membrane's ribs have been fitted in flanges 8 and 16.

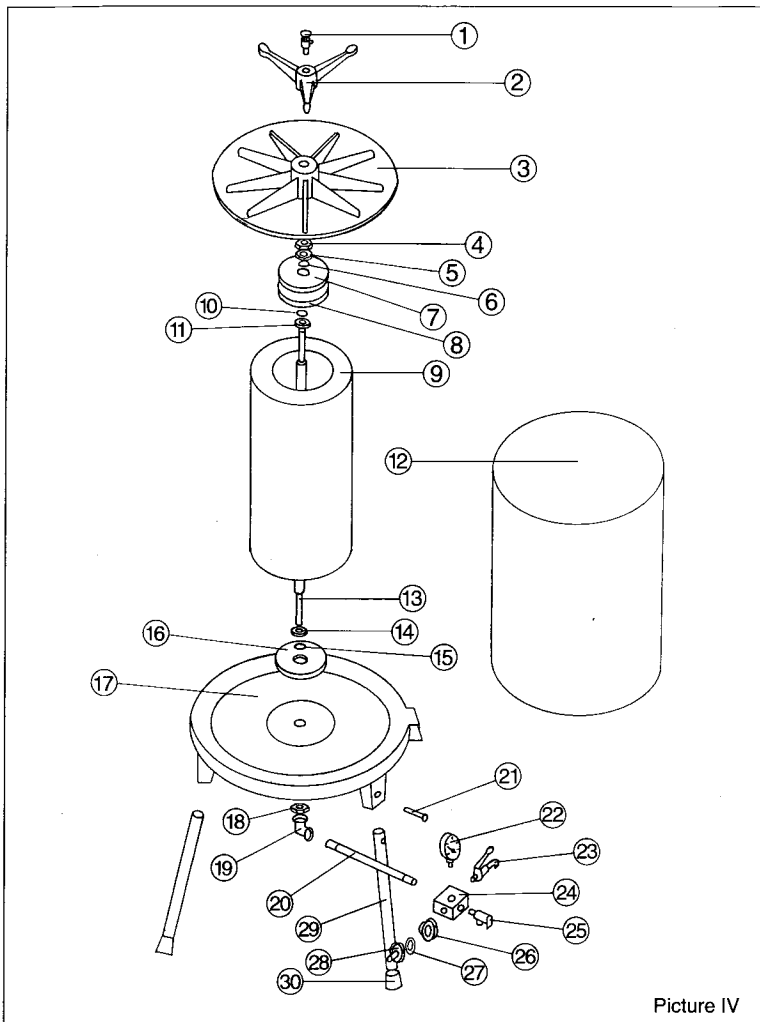

Picture IV

## 6) SPARE PARTS

### TAV. IV

- 1) Air-relief valve
- 2) Locking crank
- 3) Cover
- 4) Top locknut in stainless steel
- 5) Washer in stainless steel
- 6) Grommet
- 7) Top flange I
- 8) Top flange II
- 9) Membrane
- 10) Grommet
- 11) Washer in stainless steel
- 12) Cage
- 13) Central shaft
- 14) Washer in stainless steel
- 15) Grommet
- 16) Lower flange
- 17) Collecting base
- 18) Lower locknut in stainless steel
- 19) FF elbow
- 20) Connecting distance pipe

- 21) Leg-bolt
- 22) Pressure gauge
- 23) Emptying tap
- 24) Connecting block
- 25) Safety valve
- 26) Fast connection Swift
- 27) Gasket for fast connection
- 28) Fast connection for hose nipple
- 29) Supporting leg
- 30) Rubber cap for supporting leg