

ENOITALIA

OENOLOGICAL MACHINES

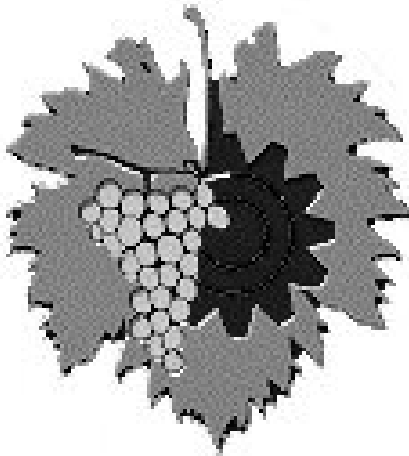

OPERATING INSTRUCTIONS AND TECHNICAL MANUAL

DESTALKING – CRUSHING MACHINE MODEL JOLLY 60/100/150 MV

ENGLISH

ENOITALIA *s.r.l.*
50050 CERRETO GUIDI (FI)
Tel.+39 0571 588031 - fax +39 0571/588080
WWW.ENOITALIA.NET INFO@ENOITALIA.NET

IMPORTANT:

This manual must be kept near the machine in a place known by the staff who will be operating it and carrying out its maintenance and repair.

CONTENTS

EC DECLARATION OF COMPLIANCE.....	2
2. SAFETY MEASURES	3
3. IDENTIFICATION PLATE	3
4. DESCRIPTION.....	6
5. INSTALLATION.....	6
6. START-UP	7
7. WASHING AND MAINTENANCE	8
8. POSSIBLE CAUSES OF MALFUNCTION	9
9. GENERAL PREVENTION RULES.....	9
10. TECHNICAL FEATURES.....	10

CONTENTS OF THE MANUAL

This manual contains full information, inclusive of drawings and/or diagrams, on the installation, operation and maintenance of the ENOITALIA Destalking-Crushing machine. It also sets out the safety measures that machine-operating staff must follow.

IMPORTANT:

The machine must not be operated by persons who have not read and fully understood the safety precautions contained in this manual.

EC DECLARATION OF COMPLIANCE

EC Declaration of Compliance
under the EEC 89/392 directive
and its subsequent changes

The undersigned company

ENOITALIA s.r.l. having its registered office in ITALY Via Prov.Pisana, 162
Cerreto Guidi (Fi)

as constructor and vendor of the machine

hereby declares under its own responsibility that the

Destalking-Crushing machine mod. JOLLY 60/100/150 MV

complies with the essential health and safety requirements of Directive EEC 89/392, 91/368/EEC, 93/44/EEC and 93/68EEC applied in Italy with DPR 459 of 24/07/1996 (Directive concerning machines)

and with the requisites of the following EEC Directives:

72/23/EEC (applied in Italy with Law 791 of 18/10/1977),

89/336/EEC e 92/31/EEC (applied in Italy with Law Decree 476 of 04/12/1992)

To ascertain the compliance with the aforementioned Directives the following harmonized EN Standards have been consulted:

292/1, 292/2, 294, 349, 418, 953, 954/1, 50100/1, 1037, 999

National regulations and technical specifications:

UNI 9450, UNI 9456, UNI ISO 1819, UNI ISO 7149, UNI 7544

Falorni Fabio

.....

2. SAFETY MEASURES

FAILURE TO RESPECT THESE INSTRUCTIONS IS DANGEROUS AS IT MAY CAUSE INJURIES TO PEOPLE AND DAMAGE TO THE MACHINE.

1.1 THE MACHINE

- The Destalking-Crushing machine supplied must be used exclusively for processing the product described herein.
- Do not start assembling and operating the Destalking-Crushing machine without having first carefully read this manual.
- Do not operate the Destalking-Crushing machine if one or more of the warning labels are damaged or missing.
- Do not operate the Destalking-Crushing machine if the protections provided have not been fitted or are missing.
- Do not start the machine if the electrical motors and/or the structure of the machine are damaged.
- At least once a year ensure that the various machine components are secured and if necessary tighten any loose nuts/bolts.
- Ensure that the circuit tension to which the engines' control panel is connected is the same as that of the engine cabling.
- When using slings to lift the machine, make sure these are suitable to the weight to be lifted.
- Do not start engines if the rotating elements are prevented from rotating freely. Ensure that machine operating staff maintain a safe distance from such rotating elements.
- Machine operation, cleaning and maintenance must be carried out exclusively by expert personnel.
- Do not leave machine on if its components are rotating in the opposite direction to that indicated by the arrows.
- Turn off and unplug the machine before carrying out cleaning, maintenance and disassembly operations.
- We thank you for choosing our machine and have pleasure in enclosing this use and maintenance manual to allow you to make the best use of the machine thus extending its service life.

This booklet must always accompany the machine. Any reproduction including partial reproduction of the same is forbidden.

3. IDENTIFICATION PLATE

	ENOITALIA s.r.l. COSTRUZIONI MECCANICHE Via Prov. Pisana, 162 50050 CERRETO GUIDI (FI) - ITALIA Tel. 0571 588031 - Fax 0571 588030	
ENO <input type="checkbox"/>	BETA <input type="checkbox"/>	MODELLO/TYPE <input type="text"/>
ARNO <input type="checkbox"/>	EURO <input type="checkbox"/>	N. SERIE/SERIAL <input type="text"/>
JOLLY <input type="checkbox"/>	GAMMA <input type="checkbox"/>	ANNO/YEAR <input type="text"/>
www.enoitalia.net		enoitalia@leonet.it

SAFETY LABELS APPLIED TO THE MACHINE

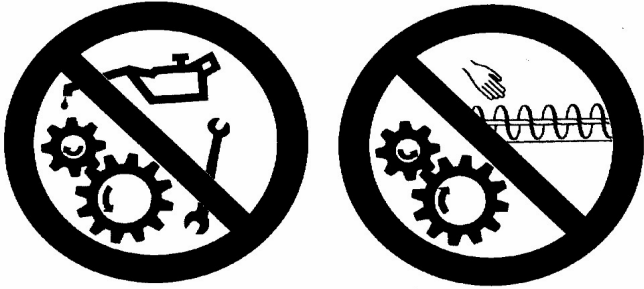

Warning: mechanical parts moving	Do not carry out maintenance work while the machine is in operation
----------------------------------	---

AUTHORIZED RESELLER TO CONTACT

MACHINE DRAWINGS

FIGURE 1

- Legend of Figure 1
- 1) Stalk outlet
 - 2) Front wheels with brake
 - 3) Collection tray with pump connection
 - 4) Speed regulation wheel
 - 5) Speed indicator

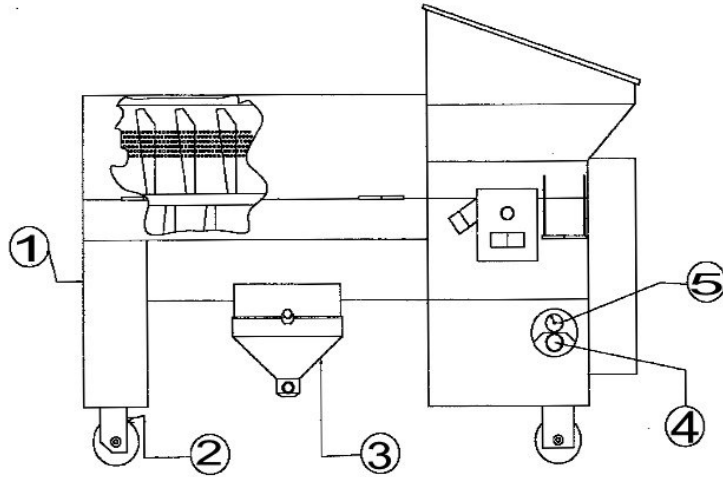

RULLIERA

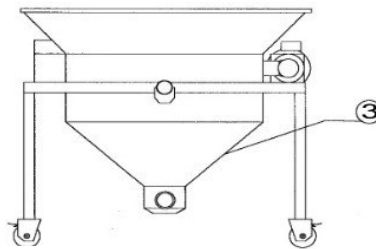
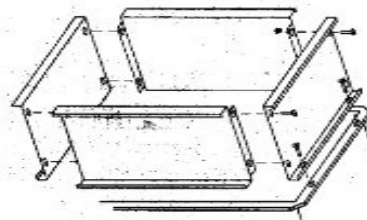
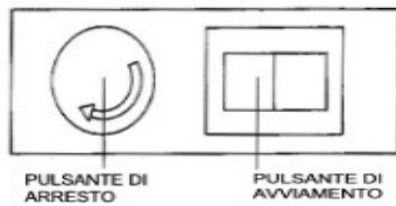

FIGURE 2

CASSONETTO ANTINFORTUNISTICO



USE OF THE MACHINE

The machine you have purchased, Model JOLLY 100 MV and 150 MV, is designed exclusively for the purpose of destalking and crushing grapes.

The constructor cannot be held responsible for any damage to the electrical or mechanical parts of the machine caused during transportation. You are therefore invited to check the condition of the packaging when the machine is delivered.

The constructor declines any responsibility in case of accidents to people or damage to things and/or the machine, caused by the operating staff's failure to strictly follow the instructions contained in this manual or from their having tampered with the machine.

Before starting the machine it is crucial that the user knows how to carry out all the operations described in this manual and to apply them whenever necessary.

4. DESCRIPTION

Below a list of machine components:-

- 1) **Infeed hopper:** contains a spiral conveyor that drags the grapes inside the destalking basket.
- 2) **Destalking basket:** separates the berries from the stems with the simultaneous rotation of the basket and of the shaker provided with rubber vanes. A screw feeder is fixed to the destalking basket which conveys the berries towards the crushing rollers.
- 3) **Roller unit:** consisting of two foodsafe rubber rollers that crush the berries. The crushing can be adjusted as required by using the wheels provided. Rollers are fixed on bearings that allow to remove the roller unit if crushing is not required.
- 4) **Must collection tank with screw feeder:** the tank receives the destalked berries, crushed if required, and conveys them by means of a screw feeder towards the hose connection to which a decanting pump should be connected. On the 1500 Kg/h models the tank is provided with wheels to make cleaning operations easier.
- 5) **Stalk outlet:** the stalks fall out of the end part of the machine. Remove only the stalks that have fallen on the ground. To remove the stalks that may have dropped on the machine's unloading plates, stop the machine, then extract the stalks.
THIS OPERATION MUST NEVER BE CARRIED OUT WHILE THE MACHINE IS ON.
- 6) **Electrical system:** this is the machine's controls panel consisting of a cable and plug, an emergency-stop device and of a machine start button. The controls panel is connected to a safety device which stops the machine when the cover is lifted. It is important that the user's electrical system complies with the law regulations in force and that its maximum power absorption is taken into account.
- 7) **Speed adjustment device:** consisting of a mechanical change drive unit in an oil bath which, by a specific wheel provided with an indicator, allows to adjust the rotating speed of all the mechanical parts of the machine (screw feeder, destalking basket, shaker). SPEED MUST BE ADJUSTED ONLY ONCE THE MACHINE HAS BEEN TURNED ON AS OTHERWISE IT MAY DAMAGE THE SPEED ADJUSTMENT DRIVE UNIT.

5. INSTALLATION

Lift the machine as indicated in the figure.

Transport the machine to the place it is to be installed in and ensure that all the wheels rest perfectly on the ground. Block the front wheels with the brakes provided (figure 1 n°2).

Remove machine from packaging and dispose of the latter in compliance with law regulations.

Make sure the floor on which the machine is to be positioned can withstand the machine's full capacity weight and that it is not inclined by more than 10%. Wash machine thoroughly to eliminate any residue and any dust on its surface.

To wash the machine, proceed as follows:-

1. Open machine cover by unscrewing the two screw fastenings and by lifting it with the handle provided.
2. Remove the stalk outlet protection by unscrewing the four screw fastenings.
3. Remove the shaker and the basket. Remove shaker shaft by turning it anticlockwise.
4. Release rollers and open the crushing unit.
5. Wash machine carefully avoiding to wet the electrical parts
6. Close the machine once washing is completed.
7. Install the anti-accident box.

OPERATION

The machine is designed to destalk the bunches of grapes that are loaded into the infeed hopper. A screw feeder conveys the bunches towards the rotating cage where the destalking takes place. The destalking speed can be adjusted by using the wheel on the speed-adjustment drive unit (figure 1 No. 4,5). Stalks are eliminated through the stalk outlet (figure 1 No. 1) whereas the berries are conveyed towards a separate outlet (figure 1 No. 3). If crushing is required the rollers may be fitted under the outlet. The destalked berries are then conveyed to the collection opening of a marc pump or in the collection tray to which a self-priming pump is connected.

6. START-UP

Important: before starting the machine, ensure that there is nothing that prevents the mechanical parts from moving freely and, above all, that nobody is close to the moving parts of the machine. More specifically, hands, arms and other body parts must be kept well away from the stalk outlet opening and from the inside of the box. Ensure that the engine voltage corresponds to the voltage of the mains.

Before start-up remember to check the oil level of the speed-adjustment drive unit and to top it up if necessary. It is important that this unit never runs dry as this would cause it break.

To start the machine, proceed with the electrical connection which must be carried out by a qualified technician. Avoid wetting the plug and socket. Should the rollers be required, plug roller unit into the electrical panel of the machine before connecting machine to the mains.

To start the machine press the start button, to stop it press the red emergency button (figure 2). Once the red emergency button has been pressed, to start the machine again rotate this button in the direction indicated by the arrow.

Once start-up has been completed, place the grapes inside the infeed hopper and set the destalking speed (figure 1, No. 4,5) by using the wheel located on the speed-adjustment drive unit (**do not use the wheel of the speed-adjustment drive unit when the engine is off as this would cause the wheel to break**). The numerical scale on the graduated dial of the wheel indicates the number of revolutions made by the motor. By using this wheel the rotation speed of the destalking shaft and of the basket can be adjusted thereby allowing a more or less gentle destalking.

The amount of bunches to be destalked depends on the screw feeder on the hopper and cannot be changed by pushing the bunches through the inlet (**this operation is of no use and should not be carried out as it is extremely dangerous**).

Should a self-priming pump be used, fit the collection tray before starting the machine. Make sure this is secured.

Should it be necessary to access the inside of the machine (in case of blockages or foreign bodies), proceed as follows:-

1. Turn off and unplug the machine.
2. Remove item from the inside of the machine by using a suitable tool and if necessary open the machine.
3. Close any open parts and repeat all start up operations.

During machine operation the user must check that there are no skins or berries still attached to the stalks at the outlet, and that there are not too many stalk fragments inside the berries collection tank. If there are stalks inside the tank, usually all that is required is to reduce the speed. If berries are still attached to the stalk at the outlet, increase the speed.

Finding the correct speed depends largely on the experience of the user as he shall have to adjust it depending on the type of grapes, on their degree of ripeness and on the type of processing these will subsequently undergo.

7. WASHING AND MAINTENANCE

After using the machine and in any case at the end of each working day, unplug the machine and wash thoroughly to eliminate any residue (see section No. 5 INSTALLATION).

To wash the machine correctly, open it and eliminate any residue inside it. To remove all residue from the rollers, these should be washed from the top and from the bottom.

Once washing is completed, if the machine is not to be used for a long period of time, proceed as follows:-

- Open the carter that protects machine gear.
- Grease all chains, internal gear, greasing points, and bearing supports
- Check the oil level of the speed-adjustment drive unit
- Close all carters and the hopper making sure that the support shaft is secured to the inside retainer.

To polish the machine's metal surface, use vaseline oil.

8. POSSIBLE CAUSES OF MALFUNCTION

PROBLEM	REMEDY
The machine has difficulty in starting.	Check that machine is receiving the correct line voltage. Do not use extension leads that are too short as this could cause a voltage reduction. Check the tension of the transmission belts with the register provided.
The machine doesn't start	Make sure machine is plugged in and that the safety microswitch is not active. Check that the machine cover is closed and secured with the fixing screws.
The crushing unit does not start.	Check if the dragging pin is well inserted.
The screw of the collection tank does not start.	See remedy above.
Some berries are still attached to the stalks at the outlet.	Turn off machine and clean the perforated tray Reduce destalking speed.
The speed-adjustment drive unit is too noisy.	Check the oil level of the speed-adjustment drive unit.

9. GENERAL PREVENTION RULES

1. The user must scrupulously follow the accident prevention regulations in force in the various countries and the instructions contained in this manual.
2. During maintenance and repair operations, remember to interrupt the electrical power connection by switching off the mains and by unplugging the machine. This operation must be carried out to avoid accidentally starting the machine which could cause injuries to people and damage to the machine.
3. Avoid moving the machine while it is in operation.
4. Machine start-up must not be carried out barefoot, with bare or soaking wet hands. Check that both plug and socket are in working order.
5. We recommend that rubber gloves, boots and an apron be worn by the user while using the machine.

PROTECTIONS

The machine is designed in such a way as to ensure that the movement of the transmission gear and of the motor are protected by carters to prevent direct contact with such parts. The machine is also provided with an anti-accident box (figure 2) which must be installed to avoid any involuntary contact with the rotating element (screw) and to allow the voluntary introduction of hands or tools as it has to permit the passage of the product.

Do not put hands or tools inside the machine when it is in operation.

The roller unit is provided with a protection grid allowing optimum product conveyance. This grid must be sufficiently wide to allow the product to pass through and to prevent the accidental contact of hands with the rollers.

The producer cannot be held responsible for any damage resulting from the tampering with or removal of the carters and of the anti-accident box.

10. TECHNICAL FEATURES

Motor: HP 2,5 / 3

Hourly production :

Mod. Jolly 60MV	4000\6000 kg/h
Mod. Jolly 100MV	7000\10000 Kg/h
Mod. Jolly 150MV	13000\15000 Kg/h

Dimensions:

Mod. Jolly 60MV	1570x840x1310 mm
Mod. Jolly 100MV	2300x1200x1500 mm
Mod. Jolly 150MV	2300x1300x1600 mm

Weight:

Mod Jolly 60MV	180 kg
Mod. Jolly 100MV	240 Kg
Mod. Jolly 150MV	280 Kg

Noise level: weighted Leq A 78,9-83,8 db. (measured outdoors in normal working conditions, in compliance with the methods indicated in UNI 7712).